

NOTE:	CPOLEE
MODEL :	CP23
CODE :	CP2 3-T
TENSION :	230 / 400V
FREQUENCE :	60Hz
I NOMINALE :	16A
WEIGHT :	260 kg



CHARACTERISTICS Polishing machine

Engine : 2.2 Kw with direct transmission
Rotation frequency: 300 to 3000 rpm
Coupling : C-Speed system for quick and flexible change.

Mounting Possibilities :

- Emery tray (.max Ø300mm)
- Polishing axis (.max L=250mm)
- Tobogan (Belt Emerying Device)

Flat base : Satin aluminium with holes threaded for fixing table-type supports steerable or other

Security : ARU on the console

Weight : 75 kg

Peak height : 170 mm

Colors : - RAL 7011 (Light Grey Textured)
 - RAL 7035 (textured dark grey)

lamp : LED 16W 5000K Waldmann (optional)

CHARACTERISTICS Vacuum bench

Fan : 1,600m³/H with 1.1Kw motor

- Filter :
- Pre-filter: G4 (forehead Access)
 - Compact filter: F7 (forehead Access)
 - Filter output: G4 (rear Access)

Electrical cabinet : integrated

Electric feet : Height 850 to 1150mm (optional)

Robot: 6-axis UR3 or UR5 (optional)

Security :

- Knee pad (UK)
- General disconnecter one hut

Footrest : (optional)

- Footrest adjustment
- Underpants

Weight : 185 kg

Quarrel : 70 dBA ±3dBA

Top : Wood with thickness = 40mm

Phenolic Coating Above/below

Colors : - RAL 7011 (Light Grey Textured)
 - RAL 7035 (textured dark grey)

Machine designed, developed, produced and assembled in Portugal

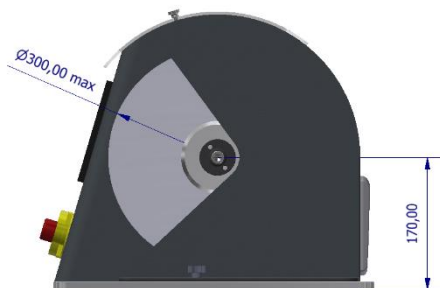
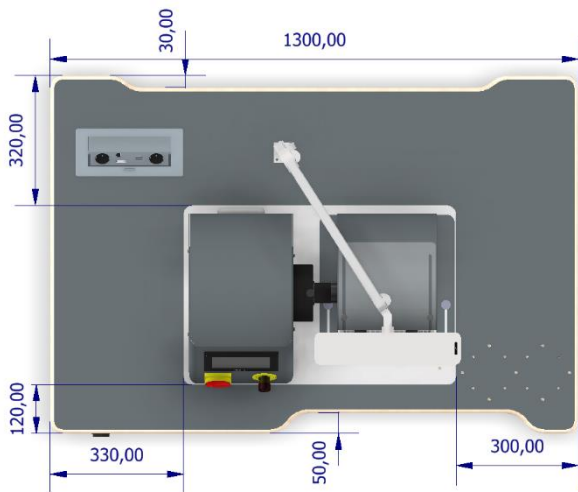
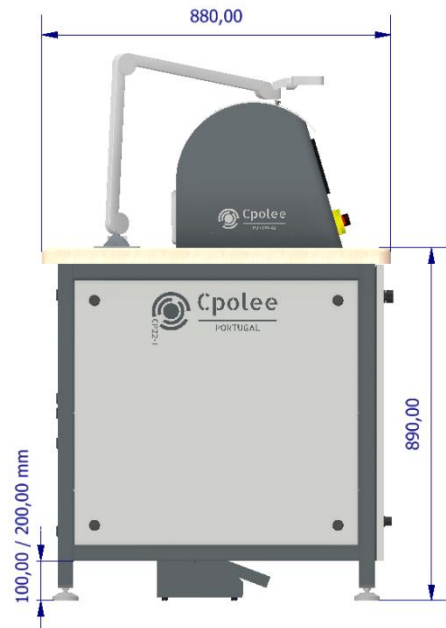
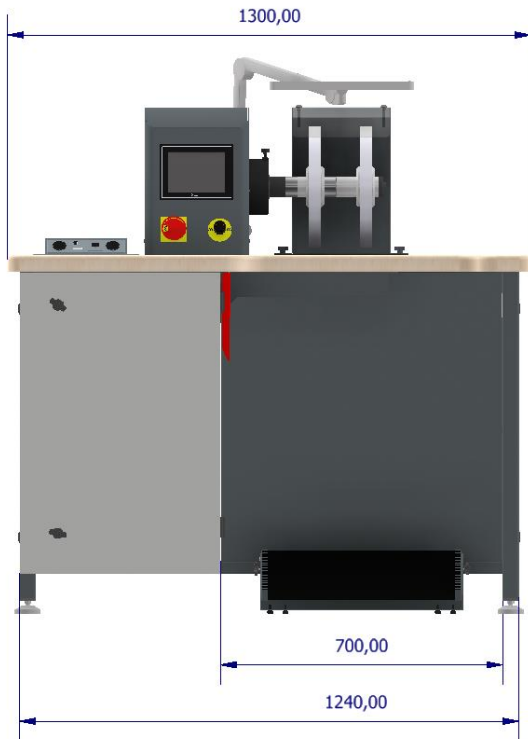

Possible configurations :

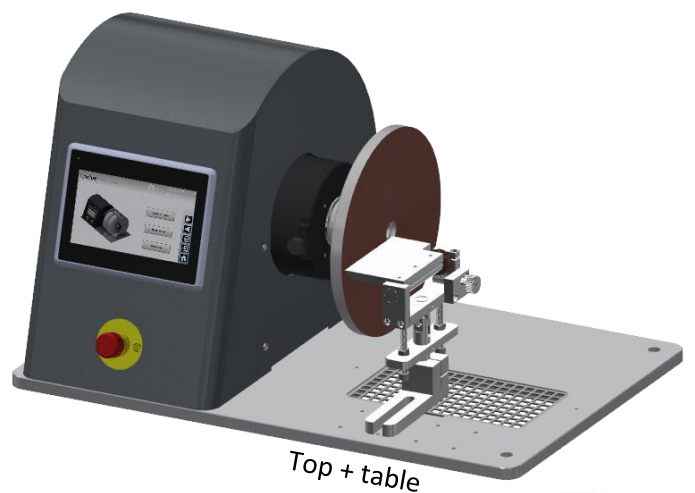
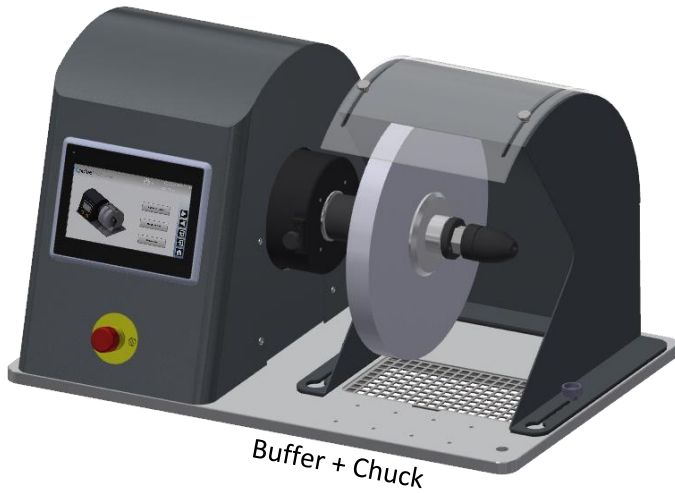
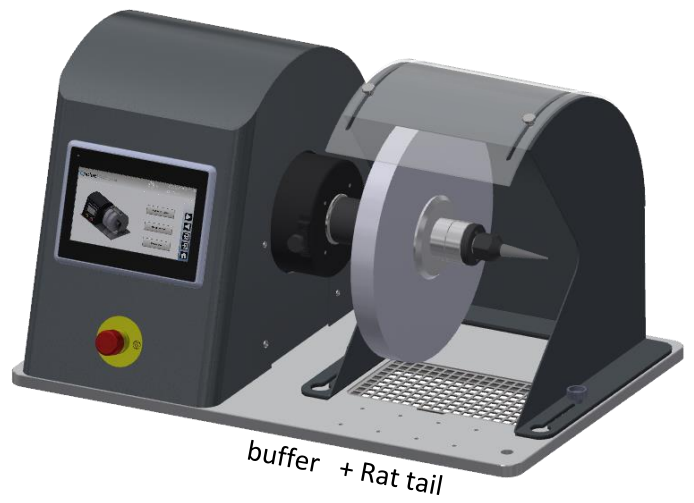
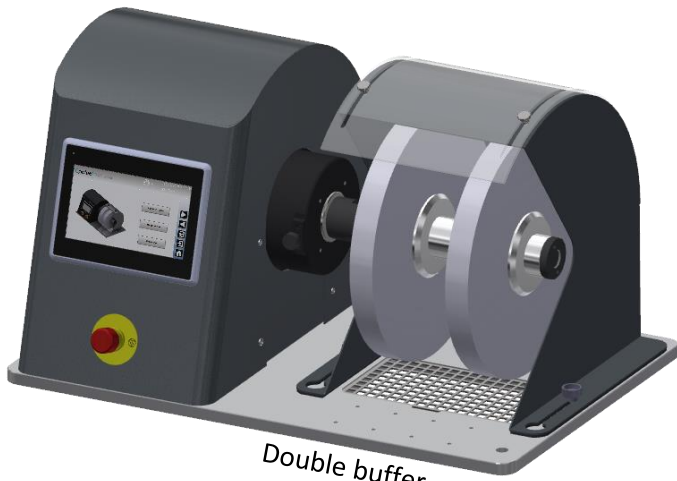

Possible integration : (on 2 different positions)

With a UR3:



With a UR5 :

